

# CS-6P

## 600mm Gas Griddle Cooktop



### Griddle

- 18 MJ/h output per 300mm module
- Stainless steel tube burners with pilot, FFD and piezo ignition
- Variable flame control valve with low flame setting
- 21mm thick mild steel griddle plate
- Griddle cooking area: 590mm x 540mm; 3200 cm<sup>2</sup>
- 2mm 304 stainless steel splash guards

### Cleaning & Servicing

- Easy access to all parts & components from front

### Options

- Rear Castors (rigid)
- Front Castors (swivel with brakes)
- Joining caps
- Ribbed or chrome finish on griddle plate
- LH and RH side shields
- Benchtop option (add -B suffix to model number)

### Warranty

- 1 Year Included + 1 Year Extendable upon registration

## PROFESSIONAL

### Specifications

- NAT GAS: 36 MJ/h, LP Gas: 36 MJ/h
- Supplied with Gas regulator (specify NAT or LP on order)
- Gas Inlet: 3/4" BSP Male
- 180mm from Right, 20mm from Rear, 600mm from Floor
- Benchtop model gas connection: 60mm from Floor
- Working Height: 900mm
- Dimensions: 600 x 800 x 1100H @ 82kg
- Packed Dimensions: 640 x 860 x 1260H @ 102kg
- Benchtop Dimensions: 600 x 800 x 560H @ 77kg
- Benchtop Packed Dimensions: 640 x 860 x 720H @ 97kg
- Heavy duty construction with 304 stainless steel external panels
- Stainless steel feet with 55mm height adjustment range
- Benchtop stainless steel feet with 20mm height adjustment range

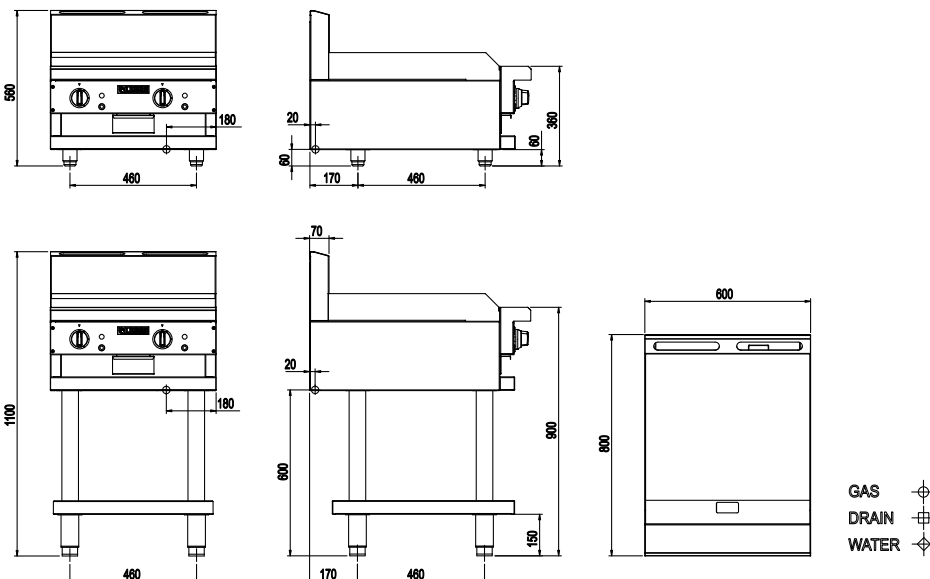

Must be installed by an authorised person in accordance with AS/NZS 3000.

Please note that specifications or design may be altered at any time without notice.

Luus Industries Pty Ltd | +61 3 9240 6822 | sales@luus.com.au | www.luus.com.au

