

EBF-40-B

400mm Benchtop Induction Fryer



INDUCTION

Specification

- Power Ratings: 5kW, 20.8A, 50Hz
- Single Phase Electrical Connection
- Hard wired or fit cable and plug (not supplied)
- 300mm from Right, 70mm from Rear, 140mm from Floor
- Protection Ratings: IPX4
- Working Height: 300mm
- Dimensions: 400 x 750 x 350H @ 30kg
- Packed Dimensions: 640 x 860 x 600H @ 10kg

Features

- 5kW power provides rapid heat recovery during cooking
- Fast and powerful with instant heat transfer to tank
- Digital thermostatic control maintains accuracy
- User friendly touch control operation with timer functions
- Lower ambient heat for a more comfortable kitchen
- 90%+ thermal efficiency results in lower energy costs
- Safer than gas with zero carbon emissions or combustion
- Durable, versatile, and easy to clean and service
- AISI grade stainless used on all external panels
- High quality engineering and craftsmanship throughout

Induction Fryer

- Approx 15kg/h production output (thawed shoestring fries)
- 5kW rapid induction high-frequency coil technology
- Accurately measures oil temperature and regulates heat
- 3 programmable temperature/timer memory settings
- Tank is separate from heat source improving uniformity
- 12 litre total tank capacity (8-10 litre min-max oil fill level)
- Consistent heating preserves oil life longer than gas fryers
- High temperature/empty tank safety mechanism
- Isolated bottom ensures user safety at all times
- Supplied with 2 fryer baskets and overnight lid

Cleaning & Servicing

- Removable baskets and filters
- Inbuilt oil drain with safety latch
- Parts & components easily accessible for servicing

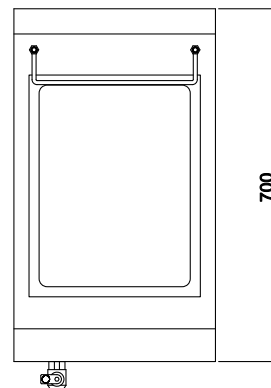
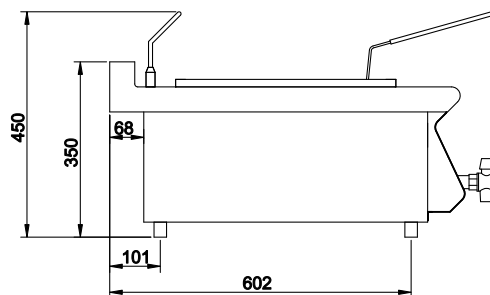
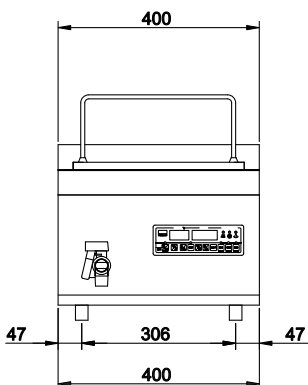

Drain 
 Water 
 Power 

Must be installed by an authorised person in accordance with AS/NZS 3000.

Please note that specifications or design may be altered at any time without notice.

Luus Industries Pty Ltd | +61 3 9240 6822 | sales@luus.com.au | www.luus.com.au



1 YEAR INCLUDED 1 YEAR EXTENDABLE UPON REGISTRATION