

EG7-12P

1200mm Induction Griddle



INDUCTION

Specifications

- Power Ratings: 16kW, 22.3A, 50Hz
- 3 Phase Electrical Connection
- Hard wired or fit cable and plug (not supplied)
- 600mm from Left, 68mm from Rear, 715mm from Floor
- Benchtop: 125mm from Floor
- Protection Ratings: IPX4
- Working height: 850mm
- Dimensions: 1200 x 750 x 1000H @ 165kg
- Packed Dimensions: 1240 x 860 x 1260H @ 180kg
- Benchtop Dimensions: 1200 x 750 x 450H @ 150kg
- Benchtop Packed Dimensions: 1240 x 860 x 600H @ 165kg

Features

- Suitable for grilling all types of meat and vegetables
- Induction tech allows rapid heating and quick recovery
- Fast and powerful with instant heat transfer to griddle plate
- Digital thermostatic control (proximate) regulates temp
- User friendly touch control operation with timer functions
- Large usable surface area with even heat distribution
- Lower ambient heat for a more comfortable kitchen
- 90%+ thermal efficiency results in lower energy costs
- Safer than gas with zero carbon emissions or combustion
- Durable, versatile, and easy to clean and service
- AISI grade stainless used in all external panels
- High quality engineering and craftsmanship throughout

Griddle

- High quality 21mm thick mild steel plate
- Rapid induction high-frequency coil technology
- Plate heats up from ambient to 200 °C in 5 minutes
- Variable heat settings with LED power display
- 6 programmable temperature/timer settings
- Dual control 2 x 600mm sections
- Thermostatic temp control regulates heat for consistency
- Evenly dispersed heating across entire cooking surface
- Integrated closed base with grease/waste sliding tray

Cleaning/Serviceing

- Parts & components easily accessible for servicing

Options/Accessories

- Rear castors
- Hard chrome (polished) plate finished surface
- Benchtop mount (add -B suffix to model number)
- Ribbed Plate Section 1/3 LHS (add -R suffix to model number)

Warranty

- 1 Year Included + 1 Year Extendable upon registration

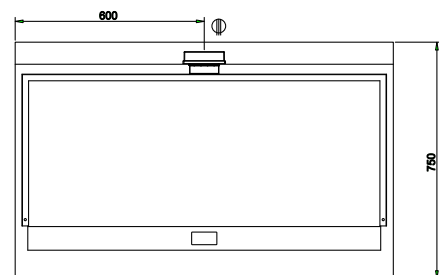
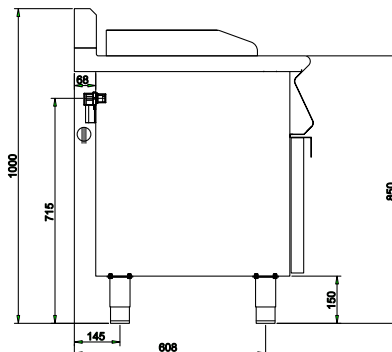
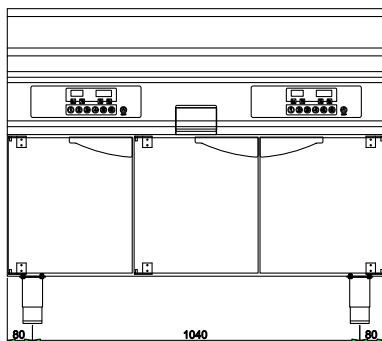
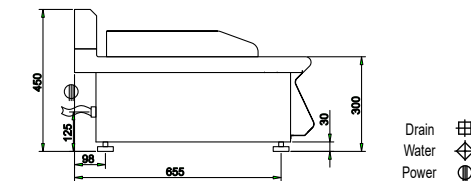
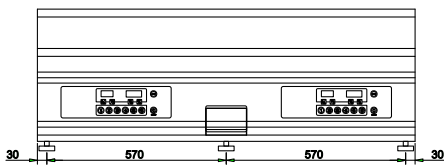

Must be installed by an authorised person in accordance with AS/NZS 3000.

Please note that specifications or design may be altered at any time without notice.

Luus Industries Pty Ltd | +61 3 9240 6822 | sales@luus.com.au | www.luus.com.au

