

EHW-1C

700mm Single Ring Large HP Induction Wok



INDUCTION

Specification

- Power Ratings: 15kW, 20.9A, 50Hz
- 3 Phase Electrical Connection
- Hard wired or fit cable and plug (not supplied)
- 350mm from Left, 68mm from Rear, 505mm from Floor
- Water Inlet: 1/2" threaded BSP male
- 53mm from Right, 222.5mm from Front, 150mm from Floor
- Drain: 2" BSP Male
- 175mm from Right, 102.5mm from Front, 150mm from Floor
- Protection Ratings: IPX4
- Working Height: 850mm
- Dimensions: 700 x 900 x 1300H @ 70kg
- Packed Dimensions: 860 x 940 x 1460H @ 80kg

Features

- Fastest and most powerful induction wok on the market
- 15kW per ring capable of boiling 2L of water in 50 seconds
- Instant heat transfer delivering unmatched performance
- Precise temperature control with visual LED display
- Achieve "wok hei" in stir-fry dishes without an open flame
- Supplied with a 500mm wok as standard inclusion
- Lower ambient heat for a more comfortable kitchen
- 90%+ thermal efficiency results in lower energy costs
- Safer than gas with zero carbon emissions or combustion
- Durable, versatile, and easy to clean and service
- AISI grade stainless used on all external panels
- High quality engineering and craftsmanship throughout
- Isolated bottom ensures user safety at all times
- SS304 one-piece pressed deck
- Front water control lever operation of rear laundry arm
- Rear condiment shelf for chef's convenience
- Zinc-aluminium alloy burner handle

Large High Powered Wok

- 15kW rapid induction high-frequency coil technology
- 6mm microcrystalline seamless and impact-resistant glass
- Large 400mm diameter glass bowl suited to 500mm+ woks
- 8 level heat settings with LED visual power display
- Auto detection turns heating off when wok is removed

Cleaning/Serviceing

- Front gutter design for easier cleaning
- Microcrystalline ceramic glass is easy to clean and maintain
- Parts & components easily accessible for servicing

Warranty

- 1 Year Included + 1 Year Extendable upon registration

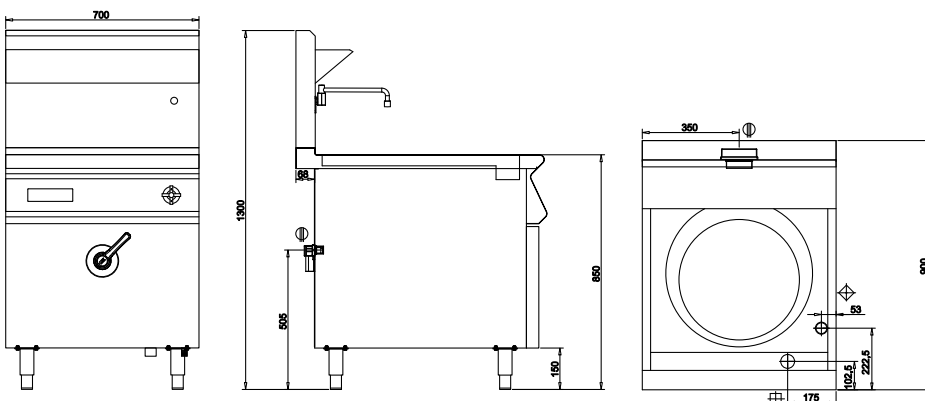

Must be installed by an authorised person in accordance with AS/NZS 3000.

Please note that specifications or design may be altered at any time without notice.

Luus Industries Pty Ltd | +61 3 9240 6822 | sales@luus.com.au | www.luus.com.au

