

EN7-40

400mm 6 Basket Induction Noodle Cooker



INDUCTION

Specification

- Power Ratings: 12kW, 17.3A, 50Hz
- 3 Phase Electrical Connection
- Hard wired or fit cable and plug (not supplied)
- 200mm from Left, 67mm from Rear, 500mm from Floor
- Water Inlet: 1/2" threaded BSP male
- 200mm from Right, 633mm from Rear, 120mm from Floor
- Drain: 1" BSP Male
- 335mm from Left, 530mm from Front, 120mm from Floor
- Protection Ratings: IPX4
- Working height: 850mm
- Dimensions: 400 x 750 x 1000H @ 65kg
- Packed Dimensions: 640 x 860 x 1260H @ 75kg

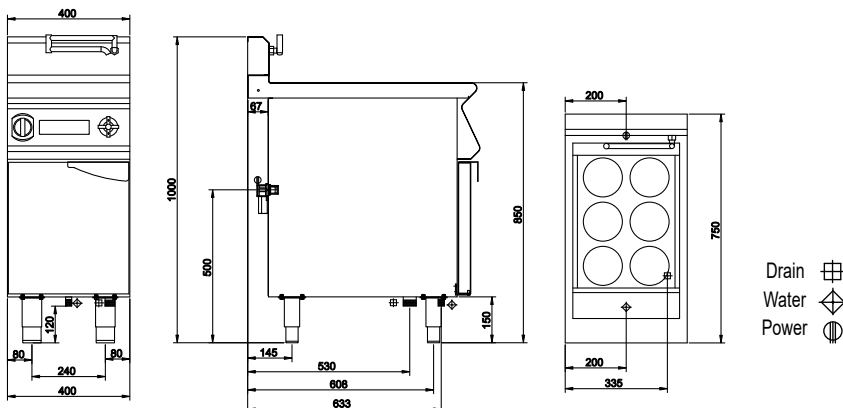

Must be installed by an authorised person in accordance with AS/NZS 3000.

Please note that specifications or design may be altered at any time without notice.

Luus Industries Pty Ltd | +61 3 9240 6822 | sales@luus.com.au | www.luus.com.au

Features

- Suitable for cooking high volumes of noodles
- Supplied with 6 round noodle baskets and basket support
- Comes to a rolling boil in 9 mins and recovers heat efficiently
- Fast and powerful with instant heat transfer to tank
- Precise temperature control with visual LED display
- Manual water refill and built-in overflow system
- Lower ambient heat for a more comfortable kitchen
- 90%+ thermal efficiency results in lower energy costs
- Safer than gas with zero carbon emissions or combustion
- AISI grade stainless used in all external panels
- High quality engineering and craftsmanship throughout

Induction Noodle Cooker

- 12kW rapid induction high-frequency coil technology
- Variable heat settings (8 levels) with LED power display
- Tank is separated from heat source improving uniformity
- Water-fill laundry arm on splashback with external tap control
- High temperature/empty tank safety mechanism
- Isolated bottom ensured user safety at all times
- Supplied with 6 noodle baskets and basket seat

Cleaning/Serviceing

- Easy access to all parts and components for servicing
- Removable baskets, basket seats and tank filter

Warranty

- 1 Year Included + 1 Year Extendable upon registration

