

# ESP-1C

## 600mm Induction Stockpot Boiler



## INDUCTION

### Specification

- Power Ratings: 15kW, 20.9A, 50Hz
- 3 Phase Electrical Connection
- Hard wired or fit cable and plug (not supplied)
- 490mm from Left, 68mm from Rear, 225mm from Floor
- Water Inlet: 1/2" threaded BSP male
- 53mm from Right, 222.5mm from Front, 85mm from Floor
- Protection Ratings: IPX4
- Working Height: 450mm
- Dimensions: 600 x 750 x 1300H @ 65kg
- Packed Dimensions: 640 x 860 x 1460H @ 75kg

### Features

- Bring stock to the boil quickly; then reduce heat to simmer
- Instant heat transfer delivering unmatched performance
- Precise temperature control with visual LED display
- 1.5mm SS304 one-piece pressed deck
- Lower ambient heat for a more comfortable kitchen
- 90%+ thermal efficiency results in lower energy costs
- Safer than gas with zero carbon emissions or combustion
- Durable, versatile, and easy to clean and service
- AISI grade stainless used in all external panels
- High quality engineering and craftsmanship throughout
- Isolated bottom ensured user safety at all times

### Single Zone Induction Stockpot Boiler

- 15kW rapid induction high-frequency coil technology
- 6mm microcrystalline seamless and impact-resistant glass
- Suitable for use with pots up to 600mm diameter (approx. 165L)
- 8 level heat settings with LED visual power display
- Auto detection turns heating off when pot is removed
- Running water accessible via rear laundry arm
- Zinc-aluminium alloy burner handle

### Cleaning & Servicing

- Easy access to all parts and components

### Options/Accessories

- Low splashback customisations
- 165L Stainless steel stockpot with release valve

### Warranty

- 1 Year Included + 1 Year Extendable upon registration

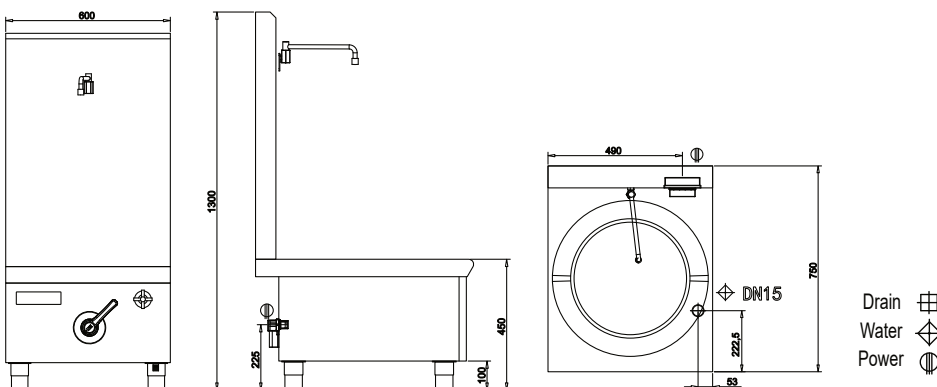

Must be installed by an authorised person in accordance with AS/NZS 3000.

Please note that specifications or design may be altered at any time without notice.

Luus Industries Pty Ltd | +61 3 9240 6822 | sales@luus.com.au | www.luus.com.au

