

ESW-2C

1200mm Double Ring Induction Wok



INDUCTION

Specification

- Power Ratings: 16kW, 22.3A, 50Hz
- 3 Phase Electrical Connection
- Hard wired or fit cable and plug (not supplied)
- 300mm from Left, 68mm from Rear, 505mm from Floor
- Water Inlet: 1/2" threaded BSP male
- 1147mm from Left, 647.5mm from Rear, 120mm from Floor
- Drain: 2" Tube
- 1025mm from Left, 530mm from Rear, 120mm from Floor
- Protection Ratings: IPX4
- Working Height: 850mm
- Dimensions: 1200 x 750 x 1300H @ 100kg
- Packed Dimensions: 1240 x 860 x 1460H @ 125kg

Features

- 8kW per ring capable of boiling 2L of water in 90 seconds
- Fast and powerful with instant heat transfer to wok
- Precise temperature control with visual LED display
- Achieve "wok hei" in stir-fry dishes without an open flame
- Supplied with a 400mm wok as standard inclusion
- 1.5mm SS304 one-piece pressed deck
- Lower ambient heat for a more comfortable kitchen
- 90%+ thermal efficiency results in lower energy costs
- Safer than gas with zero carbon emissions or combustion
- AISI grade stainless used in all external panels
- High quality engineering and craftsmanship throughout
- Isolated bottom ensured user safety at all times

Double Ring Induction Wok

- 8kW rapid induction high-frequency coil technology
- 6mm microcrystalline seamless and impact-resistant glass
- 300mm diameter glass bowl suited to 400mm+ woks
- 8 level heat settings with LED visual power display
- Auto detection turns heating off when wok is removed
- Front water control lever operation of rear laundry arm
- Rear condiment shelf for chef's convenience
- Zinc-aluminium alloy burner handle

Cleaning/Serviceing

- Front gutter design for easier cleaning
- Microcrystalline ceramic glass is easy to clean and maintain
- Parts & components easily accessible for servicing

Options/Accessories

- Low splashback customisations
- Clip on front wok holder

Wok Seasoning

- Using a low heat setting to season woks is recommended

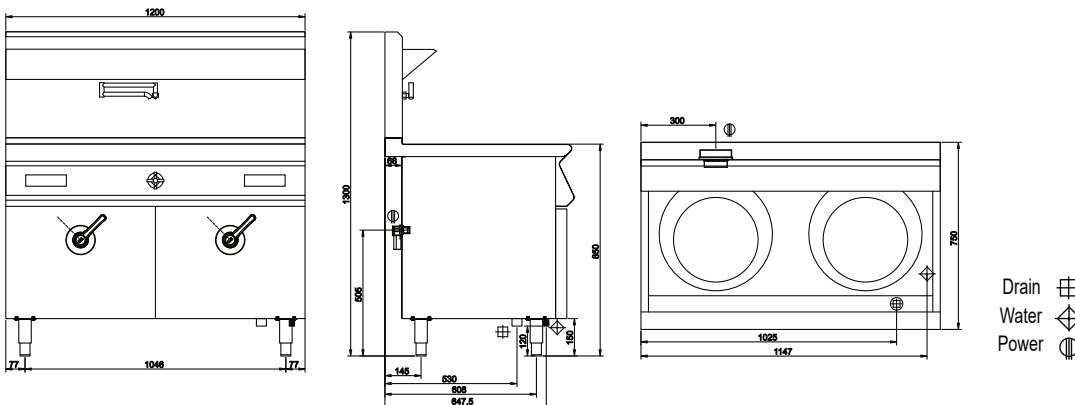

Must be installed by an authorised person in accordance with AS/NZS 3000.

Please note that specifications or design may be altered at any time without notice.

Luus Industries Pty Ltd | +61 3 9240 6822 | sales@luus.com.au | www.luus.com.au

