

EYC-70

700mm Induction Yum Cha Steamer



Features

- Suitable for cooking dim sum/dumplings/bao buns
- 20kW induction produces steam within 5 minutes of startup
- Instant heat transfer delivering high steam output
- Precise heat control with visual LED display
- Supplied with a 7-hole plate suitable for bamboo baskets
- Lower ambient heat for a more comfortable kitchen
- 90%+ thermal efficiency results in lower energy costs
- Safer than gas with zero carbon emissions or combustion
- Durable, versatile, and easy to clean and service
- AISI grade stainless used in all external panels
- High quality engineering and craftsmanship throughout
- Isolated bottom ensured user safety at all times

Steamer

- 20kW rapid induction high-frequency coil technology
- 8 level heat settings with LED visual power display
- Rapidly boils water to generate steam consistently
- Running water accessible via rear laundry arm
- Zinc-aluminium alloy burner handle

Water Treatment

- Pentair Claris N Filter supplied
- Reverse Osmosis (RO) is highly recommended in areas with high chloride content

Options/Accessories

- Low splashback customisations

Warranty

- 1 Year Included + 1 Year Extendable upon registration

INDUCTION

Specifications

- Power Ratings: 20kW, 27.8A, 50Hz
- 3 Phase Electrical Connection
- Hard wired or fit cable and plug (not supplied)
- 350mm from Left, 68mm from Rear, 505mm from Floor
- Water Inlet: 1/2" threaded BSP male
- 53mm from Right, 222.5 from Front, 150mm from Floor
- Drain: 1" BSP Female
- 265mm from Right, 305 from Front, 115 from Floor
- Protection Ratings: IPX4
- Working Height: 850mm
- Dimensions: 700 x 900 x 1300H @ 85kg
- Packed dimensions: 940 x 860 x 1460H @ 98kg

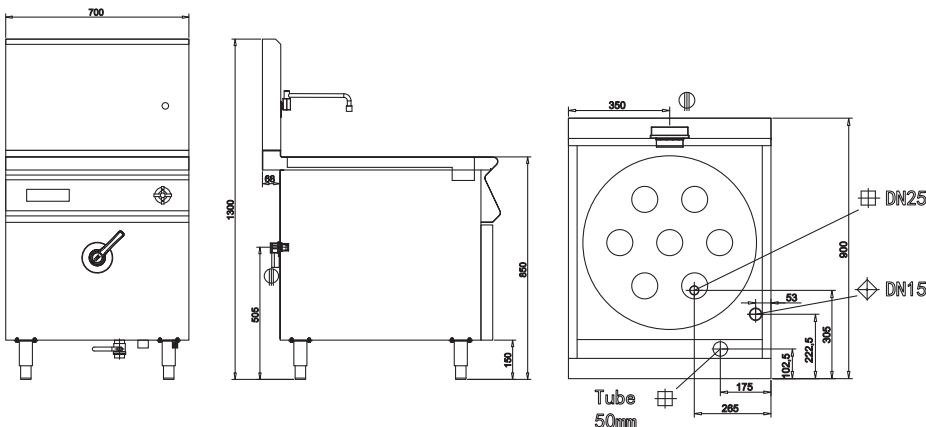

Must be installed by an authorised person in accordance with AS/NZS 3000.

Please note that specifications or design may be altered at any time without notice.

Luus Industries Pty Ltd | +61 3 9240 6822 | sales@luus.com.au | www.luus.com.au

