

# RF-2B3P

2 Burner, 300mm Griddle Gas Cooktop with Convection Oven



## PROFESSIONAL

### Specifications

- NAT GAS: 115.5 MJ/h, LP Gas: 107.5 MJ/h
- Supplied with Gas regulator (specify NAT or LP on order)
- Gas Inlet: 3/4" BSP Male
- 180mm from Left, 30mm from Rear, 140mm from Floor
- Electrical Requirements: Single Phase 220 - 240V 10A Plug, 50Hz
- 60mm from Right, 0mm from Rear, 180mm from Floor
- Working Height: 900mm
- Dimensions: 600 x 800 x 1100H @ 130kg
- Packed Dimensions: 640 x 840 x 1260H @ 150kg
- Heavy duty construction with 304 stainless steel external panels
- Stainless steel feet with 55mm height adjustment range

### Open Burners

- 2 enamelled double crown cast iron burners
- 32 MJ/h NAT Gas, 28 MJ/h LP Gas per burner
- Flame failure device standard (pilots optional extra)
- Variable flame control valve with low flame setting
- Pressed 304 stainless steel one-piece spillage bowls
- Heavy duty cast iron trivets

### Griddle

- 18 MJ/h output per 300mm module
- Stainless steel tube burners with pilot, FFD and piezo ignition
- 21mm thick mild steel griddle plate
- Griddle cooking area: 294mm x 530mm; 1600 cm<sup>2</sup>
- 2mm 304 stainless steel splash guards

### Convection Oven

- 33 MJ/h oven burner with cast iron sole plate
- Oven flame failure, pilot, and piezo ignition as standard
- Internal oven cooking space: 410mm x 585mm x 350mm H
- 100-340 °C thermostatically controlled fan forced oven
- Side mounted fan improves heat circulation
- Ceramic Rockwool insulated oven walls and doors
- Drop down door for easy oven access
- 304 stainless steel 'cool touch' door handles
- Suits 1/1 Gastronorm size trays
- Supplied with 2 chrome oven racks with 4 rack support positions

### Cleaning & Servicing

- Removable burners, hoods and spillage bowls
- Secondary undertray to catch any additional waste
- Oven racks, supports and sole plate easily removable
- Easy access to all parts and components from front

### Options/Accessories

- Rear Castors (rigid)
- Front Castors (swivel with brakes)
- Pilots for open burners
- Ribbed or chrome finish on griddle plate
- LH and RH side shields
- Drop on griddle plate covering 2 open burners
- Plinth mounting

### Warranty

- 1 Year Included + 1 Year Extendable upon registration

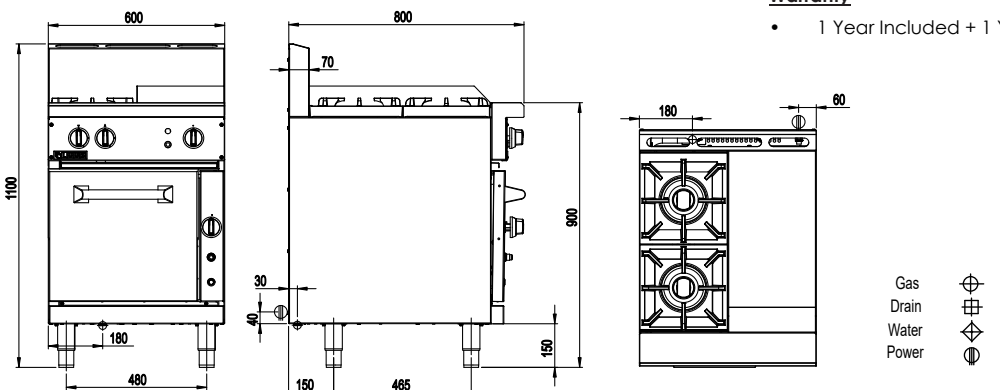

Must be installed by an authorised person in accordance with AS/NZS 3000.

Please note that specifications or design may be altered at any time without notice.

Luus Industries Pty Ltd | +61 3 9240 6822 | sales@luus.com.au | www.luus.com.au

