

SM-90

900mm Gas Salamander



Griller/Toaster

- 11 MJ/h infrared burners with Pilot, FFD, and piezo ignition
- Variable flame control valve with low flame setting
- Supplied with 1 chrome rack with handles
- Multiple (3) toasting rack positions
- Toasting rack: 740 x 320mm
- Crumb tray at base of toaster
- Infrared burners do not cause 'drying' effect
- Optimal toasting results with burner on 'high' setting
- Lower flame settings ideal for melts/warming
- Standard with heavy duty wall mounting brackets

Cleaning & Servicing

- Removable toaster rack tray and supports
- Easy access to all parts and components from front

Warranty

- 1 Year Included + 1 Year Extendable upon registration

PROFESSIONAL

Specifications

- NAT Gas: 33 MJ/h, LP Gas: 33 MJ/h
- Supplied with Gas regulator (specify NAT or LP on order)
- Gas Inlet: 1/2" BSP Male
- 80mm from Right, 0mm from Rear, 120mm from Floor
- Dimensions: 900 x 445 x 560H @ 47kg
- Packed Dimensions: 960 x 510 x 750H @ 67kg
- Heavy duty construction with 304 stainless steel panels
- Stainless steel feet with 20mm height adjustment range

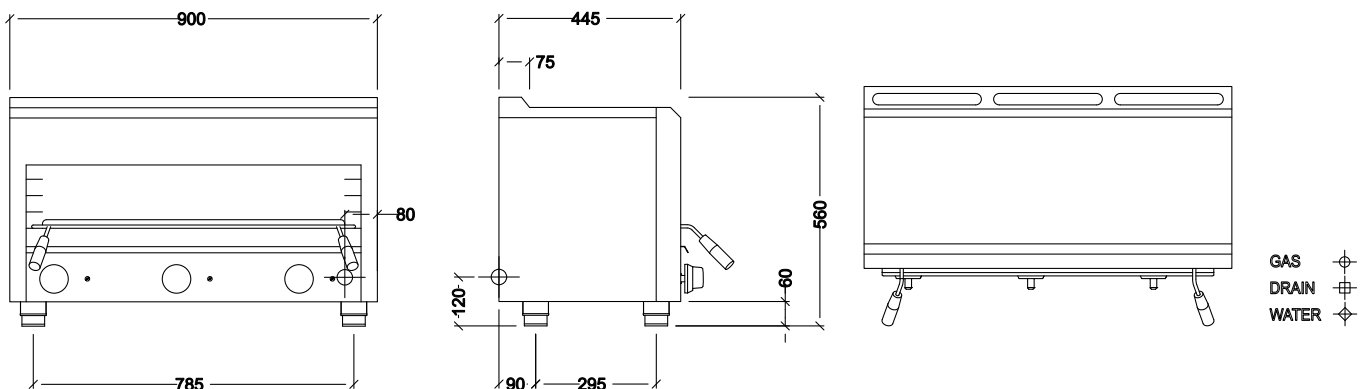

Must be installed by an authorised person in accordance with AS/NZS 3000.

Please note that specifications or design may be altered at any time without notice.

Luus Industries Pty Ltd | +61 3 9240 6822 | sales@luus.com.au | www.luus.com.au

