

WX 600mm Compact Stockpots



Technical Specifications for WX-1SP



- Space saving 800mm depth
- Suitable for use with Luus 1.65lt stockpot
- Duckbill burners ideal for high heat/fast stir frying
- Air gap design eliminates need for water cooling
- Cast iron trivet aids airflow and burner combustion
- Machine pressed deck to prevent grime catchment
- Concealed ring lip prevents water from entering air gap
- Folding laundry arm for flexible usage positions
- Optional Chimney Burners no additional cost
- 15 month 'Platinum Warranty'
- Easy to clean and service

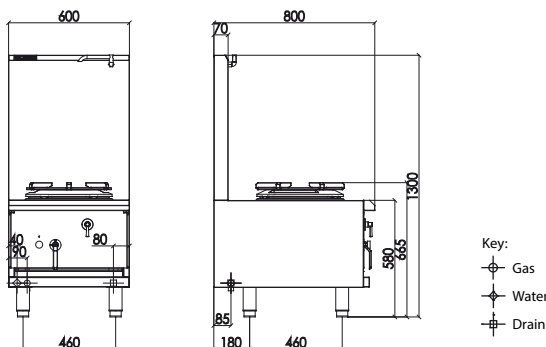

Compact Stockpot

- 90 mj jet duckbill burners with pilot & FFD
- Supplied with heavy duty cast iron trivet
- Air gap cooling system
- Quarter turn water control lever
- Folding rear laundry arm with front panel controls
- Front gutter design for easier cleaning
- Internal front heat shield panel
- Zinc-aluminium Alloy burner handles

Overall Construction

- Heavy duty construction
- Full skirt, enamelled cast-iron rings
- 1.5mm 304 stainless steel one-piece pressed deck
- 0.9mm 304 stainless steel condiment shelf
- Splashback 1.2 mm stainless steel
- Front cover and hob 1.2mm stainless steel
- Side panels 0.9mm stainless steel
- Undertrays 0.7mm stainless steel
- Stainless steel legs with 55mm height adjustment range

Dimensions

- 600mm x 800mm x 1300mm H
- Working height 600mm
- Weight 85kg
- Packed dimensions 650mm x 900mm x 1470mm H
- Packed weight 110kg

Connections

- Gas 3/4" BSP male
- Gas 90mm from left, 85mm from rear, 185mm to floor
- Supplied with gas regulator (specify Nat or LP on order)
- Water inlet 1/2" copper tube
- Water 40mm from left, 85mm to rear, 185mm to floor
- Drain 1 1/4" BSP male
- Drain 80mm from right, 85mm from rear, 185mm to floor

Cleaning & Servicing

- Easy access to all parts & components from front

Options/Accessories

- Knee lever timer tap
- Replace Duckbill burners with Chimney burners
- 250mm and 500mm wide clip on shelves
- Joining caps & strips
- RH and LH side shields
- Rear castors

	Model	Description	Nat Gas	LP Gas
	WX-1SP	1 duckbill burner stockpot	90 mj	90 mj

